

# ሐርጫዊ ትሕዝቶ ዘለዎ ወሃቢ ትንፋስ

## ጀኑኤየር (Genuair)

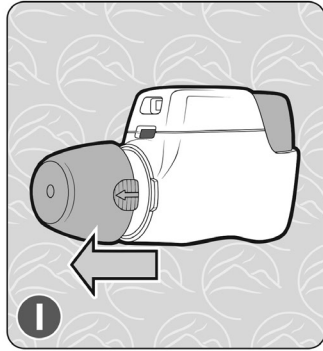

1

መኽደኒ እለዩ

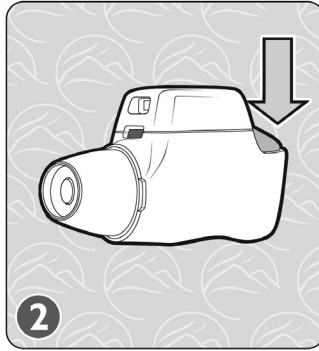

2

ቀጠልያ መጠወቂ ጽቕጡ

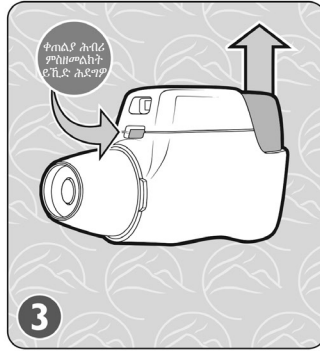

3

ቀጠልያ መጠወቂ ፈንወ



4

ንግዳም አተንፍሱ



5

ብሓይሊ ንውሽጢ አተንፍሱ



6

መዘኻኸሪ

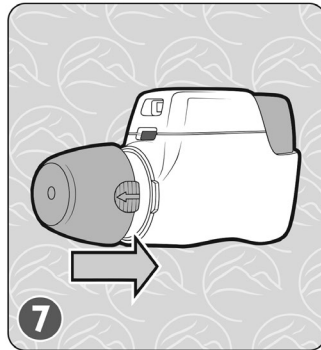

7

መኽደኒ ናብ ቦታኡ ምለስዎ

### አገዳሲ ሐበሬታ

- አስተውዕሉ:- ንመውዓሊ-አፍ ኣብ ሞንጎ አስናንኩም ጌርኩም ከናፍርኩም ዕጸዉ።
- ጥርሑ?:- መስኮት ሐበሬታ ዓቕን ዝሕብሩ ኣሃዛት ኣለውዎ - “0” ትሕዝቶ ጥርሑ ኣሎ ማለት እዩ። ደርብይዎ።
- ዕድመ ኣገልግሎት ንብረት ኣብቂዑ?:- ኣብ ጐድኒ ናይ’ቲ ኣቕሓ ንዝተጻሕፈ - ዕድመ ኣገልግሎት ንብረት ዘብቅዓሉ ዕለት ፈትኹ።
- መዘኻኸሪታት:- ነዚ ኣቕሓ ኣብ ድሩቕ ኮነታት ዓቅብዎ።  
ናብ ውሽጢ እዚ መሳርሒ እዚ ኣይተተንፍሱ።  
ምስተጠቐምኩም ንመኽደኒ ናብ ቦታኡ ምለስዎ።  
አገባብ ኣጸራርዩ:- ንመውዓሊ-አፍ ብንቕጽ ጨርቂ ጥራይ ከትውልውልዎ/ከተጸራርይዎ ይግባእ።  
ኣብ ነፍሲወከፍ 12 ሰዓታት ውሰድዎ።  
ዓሚቕ ትንፋስ ኣብ እትሰሕቡሉ እዋን፡ መስኮት ሐበሬታ ሕብሩ ናብ ቀይሕ ክቕየር ይግባእ።  
ሕብሩ ገና ቀጠልያ ኩይኑ ምስጸንሕ፡ ነቲ ቀጠልያ መጠወቂ ከምዘፈነኹም ብምርግጋጽ፡ ንቕደም-ተኸተላት ቀ. 4-5 ድገምዎም።
- እዚ ጽሑፍ እዚ ሐበሬታ ንምሃብ ጥራይ ተባሂሉ ዝተዳለወ እዩ። ከም መተካእታ ናይ ሕክምናዊ ምኽሪ፡ መምርሒ ድዩስ ፍወሳ ከውሰድ ኣይግባእን። ፍልይ ዝበሉ ሕቶታት ምስዝህልዉኹም፡ ብኸብረትኩም ምስ ደክተርኩም ወይ ምስ ዝምልከቶ ሰራሕተኛ ኣገልግሎት ክንክን ጥዕና ተዛራርቡ።
- ብኮም ኣገልግሎታት ሕማማት ሽኩርን ኣዝማን ዝተዳለዉ መብርሂታት:- [www.ucalgary.ca/icancontrolasthma](http://www.ucalgary.ca/icancontrolasthma)

ነቶም ብትንፋስ ዝውሰዱ መድሃኒታት ድዩስ ንአገባብ ኣጠቓቕማ መሳርሒታቶም ብዝምልከት ተወሳኺ ሐበሬታ ንምርካብ፡ ኣብ ነቕጣ መርበብ ሐበሬታና ፈትኹ:- [www.ucalgary.ca/asthma](http://www.ucalgary.ca/asthma)



ሓገዝቲ ክኹኑ ዝኸእሉ እዋናውያን መምርሒታት አተናፍሳ

